

# EH2100/EH2100P Enclosure

## INDOOR, IN-CEILING, FOR SINGLE CAMERA

### Product Features

- Low Profile, "Wedge" Style
- Designed for Medium-to-Large Format Cameras
- For Use in Fixed or Dropped (False) Ceilings
- Hinged Door Opens for Convenient Access to Camera
- Select from Riveted or Fully Welded and Sealed Back Box Models



**EH2100 MOUNTED IN DROPPED CEILING  
USING E2100 MOUNTING PLATE**

The **EH2100** and **EH2100P** are low profile ceiling enclosures designed for use with medium-to-large format cameras. The unobtrusive, compact design complements any business or office decor.

The enclosures are designed for use in fixed or dropped (false) ceilings. The upper section mounted above the ceiling is constructed of aluminum. The **EH2100** has a riveted back box and the **EH2100P** has a fully welded and sealed back box.

Because of its lightweight design, the enclosure can be mounted directly on a ceiling tile without the use of an additional mounting plate. Pelco offers an optional 360-degree rotating mounting plate (**E2100**) for false ceiling applications, which allows the enclosure to be rotated in 10-degree increments to change the viewing area.

The **EH2100** and **EH2100P** are engineered for ease of installation and service. The lower section is hinged to provide convenient access for camera and lens adjustments. The adjustable camera mounting sled allows the camera to be positioned vertically or horizontally, depending on the camera size. A Phillips head screw at the front of the enclosure secures the cover.

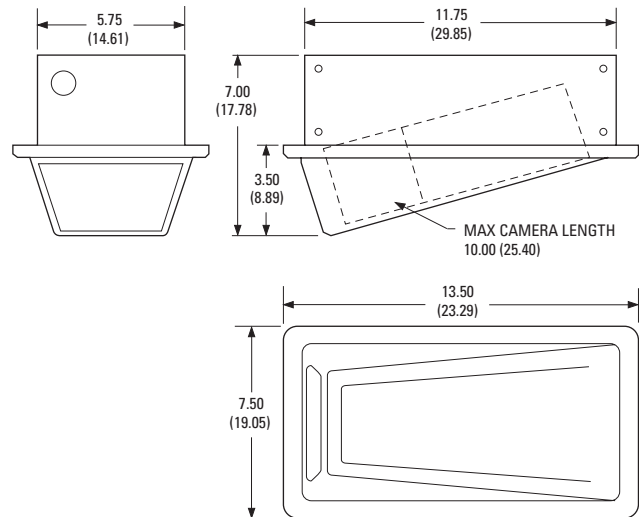

NOTE: VALUES IN PARENTHESES ARE CENTIMETERS;  
ALL OTHERS ARE INCHES.



DataFAX  
SPEC: 2407

MANUAL: 24076 (EH2100, EH2100P), 24056 (E2100)

C407 / REVISED 10-02



International Standards  
Organization Registered  
Firm ISO 9001 Quality System



# TECHNICAL SPECIFICATIONS

## MODELS

|         |   |
|---------|---|
| EH2100  | Low profile ceiling enclosure with riveted back box; for use in fixed or false ceiling applications |
| EH2100P | Same as EH2100 except has fully welded and sealed back box  |

*Note: The EH2100 is also available in a heavy-duty version constructed from steel and aluminum for maximum protection and durability. See HS2100 specification sheet for additional information.*

## MECHANICAL

|                              |   |
|------------------------------|---|
| Camera Mounting              | Adjustable camera sled capable of supporting a maximum weight of 10 lb (4.53 kg). Sled can be adjusted horizontally or vertically |
| Maximum Camera and Lens Size | Accepts camera and lens combinations* (including BNC connector) up to:<br>3" H x 4" W x 10" L<br>(7.62 x 10.16 x 25.4 cm)         |
| Ceiling Mounting             | Upper section flange-mounted to fixed ceiling or ceiling tile. Ceiling support rails are provided                                 |
| Cable Entry                  | Conduit knockouts, EH2100 only; must be drilled for EH2100P   |
| Lock                         | Phillips head screw   |

\*Assumes lens is fully extended.

## GENERAL

|                 |                                |  |
|-----------------|--------------------------------|--|
| Construction    | Upper section<br>Lower section | 5052H32 aluminum<br>Vacuum-formed ABS plastic (UL listed material) |
| Viewing Window  |                                | Lucite® SAR (Super Abrasion Resistant) acrylic                     |
| Color           | Upper section<br>Lower section | Alodine<br>Eggshell white ABS plastic                              |
| Environment     |                                | Indoor; 32° to 120°F (0° to 49°C)                                  |
| Unit Weight     | EH2100<br>EH2100P<br>E2100     | 2.47 lb (1.12 kg)<br>2.48 lb (1.13 kg)<br>3.10 lb (1.41 kg)        |
| Shipping Weight | EH2100<br>EH2100P<br>E2100     | 4 lb (1.81 kg)<br>4 lb (1.81 kg)<br>5 lb (2.26 kg)                 |

## CERTIFICATIONS/RATINGS

- UL Listed
- Meets NEMA 1 Standards

## OPTIONAL ACCESSORIES

|       |   |
|-------|---|
| E2100 | 360° rotating mounting plate; rotates in 10° increments and features locking capability to secure enclosure positioning. Replaces 2-ft x 2-ft (61 cm x 61 cm) ceiling tile; can be used in 2-ft x 4-ft (61 cm x 122 cm) ceiling tile with additional "T" rail for support. Constructed of aluminum with textured white polyester powder coat finish |
|-------|---|

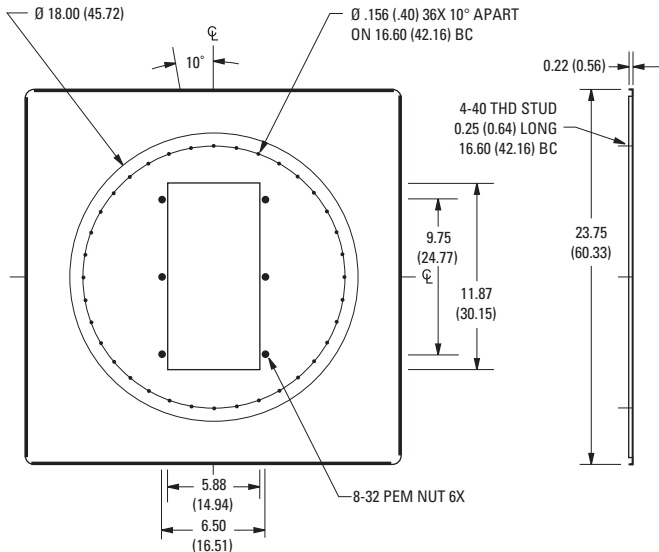

NOTE: VALUES IN PARENTHESES ARE CENTIMETERS; ALL OTHERS ARE INCHES.



**E2100 ROTATING MOUNTING PLATE**



### Pelco Worldwide Headquarters:

3500 Pelco Way, Clovis, California 93612-5699 USA

**USA & Canada** Tel: (800) 289-9100 • FAX (800) 289-9150 • DataFAX (800) 289-9108

**International** Tel: (559) 292-1981 • FAX (559) 348-1120 • DataFAX (559) 292-0435

[www.pelco.com](http://www.pelco.com)

Lucite® is a registered trademark of DuPont. Specifications subject to change without notice. ©Copyright 2002, Pelco. All rights reserved.